

# 1000-VA DC-TO-AC INVERTER

## 120-VAC, 60-Hz OUTPUT



Model 1735-48-120-60-U

### FEATURES

- 24, 48 OR 130 VDC INPUT
- ISOLATED, REGULATED FREQUENCY-STABLE OUTPUT
- APPROX. 90% EFFICIENT
- RUGGED, CONSERVATIVE DESIGN
- AVAILABLE WITH INTEGRAL HIGH-SPEED TRANSFER SWITCH FOR UPS/STANDBY-POWER APPLICATIONS

Compact and rugged, the 1000-VA Model 1735 dc-to-ac inverter is designed to perform equally well in stationary and mobile applications. The inverter provides an isolated, regulated 120-Vac, frequency-stable 60-Hz quasi-sine-wave output and is available in 24, 48 and 130-Vdc input versions. The conservatively rated Model 1735 can operate continuously at maximum rated power over a -10°C to +50°C ambient temperature range. It is well suited for powering a variety of loads, from sensitive electronic equipment to small motors and nonlinear loads normally considered difficult for inverters.

The Model 1735 is available as a plain inverter or with built-in automatic load switchover features to permit operation in UPS or standby-power modes.

Table 1

Nominal Input Voltage (Vdc)	Input Voltage Range (Vdc)	Input Current No Load <sup>1</sup> (A <sub>dc</sub> )	Input Current Full Load <sup>2</sup> (A <sub>dc</sub> )	Model Number <sup>3</sup>
24	21-29	0.6	50	1735-24-120-60
48	42-58	0.2	25	1735-48-120-60
130	105-145	0.17	10	1735-130-120-60

<sup>1</sup>Typical plain inverter (-P) at nominal input voltage

<sup>2</sup>Typical at minimum input voltage

<sup>3</sup>See reverse side for complete model numbering information

## SPECIFICATIONS

### Input Voltage and Current

The nominal input voltage, the input voltage range, the no-load input current and the full-load input current are shown in Table 1.

### Output Voltage

120 Vac nominal, single phase

### Frequency

60 Hz nominal.  $\pm 0.25$  Hz maximum variation over the full range of load and input voltage changes. Temperature coefficient is  $\pm 0.02\%$  maximum per  $^{\circ}\text{C}$ .

### Volt-Ampere Rating

1000 VA

### Output Voltage Regulation

Approx.  $\pm 5\%$

### Output Voltage Wave Shape

Three-level stepped approximation to a sine wave with peak, average and rms values approximating those of a sine wave.

### Temperature Range

Operating:  $-10^{\circ}\text{C}$  to  $+50^{\circ}\text{C}$   
Storage:  $-40^{\circ}\text{C}$  to  $+95^{\circ}\text{C}$

### Protection

Protection against overloads and accidental short-circuit of the output is provided electronically, and recovery is automatic upon removal of the abnormal load.

### Front-Panel Controls and Indicators

A combination circuit breaker and ON/OFF switch is provided for input power. L and U versions include three LED status indicators.

### Mechanical Description

Figure 1 provides overall dimensions. Weight is approximately 13 lbs. Mounting flange on base accepts eight #10 screws.

### Standard Configurations

**P VERSION:** Adding the suffix **P** to the basic model designates a plain inverter, i.e. a unit with no internal inverter-to-line or line-to-inverter transfer switching provisions. ("Line" refers to commercial ac power.) This version does not have the three front-panel LED status indicators or alarm contacts.

**U VERSION:** Adding the suffix **U** to the basic model number designates the inverter-preferred UPS configuration.

In this configuration, the load power is normally provided by the inverter. However, if the inverter output is interrupted, an internal transfer switch automatically transfers the load from the inverter to commercial ac power. The transfer time between inverter and line is short (2 msec. typical) and such transfers are normally not detected by even highly sensitive loads. Upon restoration of inverter power, transfer back to inverter power automatically takes place within a few seconds. This version includes three front-panel LED status indicators and auxiliary Form C contacts for remote indication of alarm conditions.

**L VERSION:** Adding the suffix **L** to the basic model number designates a unit which is identical to the "U" version except that, in the "L" configuration, the load power is normally provided by the commercial ac line and the inverter operates in the standby mode. If commercial ac power is interrupted, an internal transfer switch automatically transfers the load to the inverter. Upon restoration of commercial ac power, there is a delay of approximately five seconds, the load is then transferred back to commercial ac

power and the inverter again operates in the standby mode. Other features such as transfer speed, alarms, indicators, etc. are the same as in the "U" version.

### Model Numbering Information

For ordering purposes the Model 1735 should be identified by an expanded model number consisting of four numbers followed by a letter suffix. In sequence, they designate:

- basic 1000 VA inverter type (1735)
- nominal input voltage (24, 48 or 130)
- nominal output voltage (120)
- output frequency (60)
- configuration (P, U or L version)

For example, the correct part number for a 48-volt input, inverter-preferred UPS configuration is Model 1735-48-120-60-U

### OTHER WILMORE PRODUCTS

For information about other Wilmore dc-to-ac inverters or for information about other power-conditioning products such as switching power supplies, dc-to-dc converters, and uninterruptible power systems, please contact our sales department.

Information provided in this preliminary bulletin is subject to change without notice.

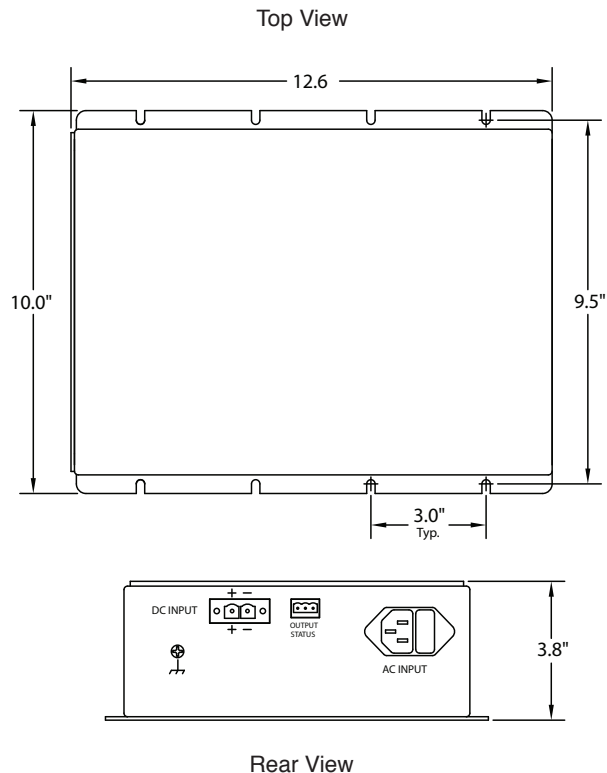

Fig. 1 Overall dimensions. Inverter shown is U or L version.

**WILMORE ELECTRONICS COMPANY, INC.**

P. O. Box 1329, Hillsborough, N. C. 27278 • Telephone (919) 732-9351 • FAX (919) 732-9359

[www.wilmoreelectronics.com](http://www.wilmoreelectronics.com)